

面板安装开孔图
Panel cut out

技术参数:

插芯:

- 插针数: 10+PE
 - 额定电流: 16A
 - 额定电压: 250V
 - 额定脉冲电压: 4kV
 - 污染等级: 3
 - 依据UL/CSA的额定电压: 600V
 - 绝缘阻抗: $>10^{10}\Omega$
 - 材料: 聚碳酸酯
 - 颜色: RAL 7032 (浅灰色)
 - 温度范围: $-40^{\circ}\text{C} - +125^{\circ}\text{C}$
 - 依据UL 94的阻燃等级: V0
 - 可插拔次数: >500
- 插针:
- 接线方式: 螺钉连接
 - 材料: 铜合金
 - 表面处理: 镀银
 - 接触电阻: $<1\text{m}\Omega$
 - 线径范围: $0.75-2.5\text{mm}^2(18-14\text{ AWG})$
 - 拧紧/检测力矩: $0.5\text{N}\cdot\text{m}$

Technical specification:

Inserts:

- No. of contact: 10+PE
- Rated current: 16A
- Rated voltage: 250V
- Rated impulse voltage: 4kV
- Pollution degree: 3
- Rated voltage acc.to UL/CSA: 600V
- Insulation resistance: $>10^{10}\Omega$
- Material: polycarbonate
- Colour: RAL 7032(light grey)
- Temperature range: $-40^{\circ}\text{C} - +125^{\circ}\text{C}$
- Flammability acc.to UL 94: V0
- Mating cycles: >500

Contacts:

- Terminal: screw terminal
- Material: copper alloy
- Surface: hard-silver plated
- Contact resistance: $<1\text{m}\Omega$
- Wire gauge: $0.75-2.5\text{mm}^2(18-14\text{ AWG})$
- Tightening/Test torque: $0.5\text{N}\cdot\text{m}$

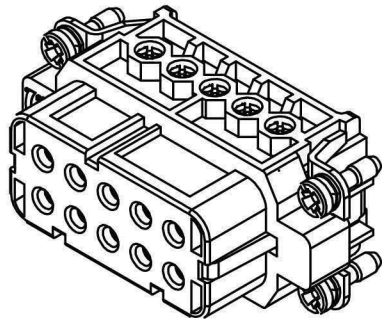

						表面处理 Finish		-		图号 Drawing No.	-
						材料 Material		-		产品代号 Part Code	HA-010-F
标记 Mark	处数 Number	变更描述/Description		签名 Signature	日期 Date	比例 Scale		版本 REV.	重量 Weight	数量 Qty.	产品料号 Part No.
绘图 Drawn		姓名/Name	日期/Date	姓名/Name	日期/Date	3:4	V1.0	45.8g	-		产品名称 Part Name
审核 Checked								All Dimensions in mm Original Size DIN A 4		沈阳思源科技有限公司 Shenyang Simuyuan Technology Co., Ltd	
工艺 Process	-			批准 Approved							