

| 产品代号 Part Code | 产品料号 Part NO. | 重量/Weight | | | 线径/Wire Gauge | | | 剥线长度 Stripping Length |
|-------------------|------------------|-----------|-----------------|-------|---------------|-----|---|--------------------------|
| | | g | mm ² | AWG | d | D | h | |
| CDSF-0.37 | | 0.74 | 0.14-0.37 | 26-22 | 0.9 | 2.6 | 8 | 8 |
| CDSF-0.50 | | 0.72 | 0.5 | 20 | 1.15 | 2.6 | 8 | 8 |
| CDSF-0.75 | | 0.70 | 0.75 | 18 | 1.3 | 2.6 | 8 | 8 |
| CDSF-1.0 | | 0.68 | 1.0 | 18 | 1.45 | 2.6 | 8 | 8 |
| CDSF-1.5 | | 0.67 | 1.5 | 16 | 1.75 | 3.0 | 8 | 8 |
| CDSF-2.5 | | 0.63 | 2.5 | 14 | 2.25 | 3.2 | 6 | 6 |

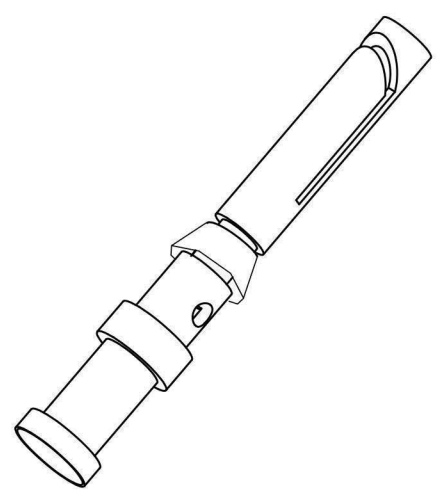
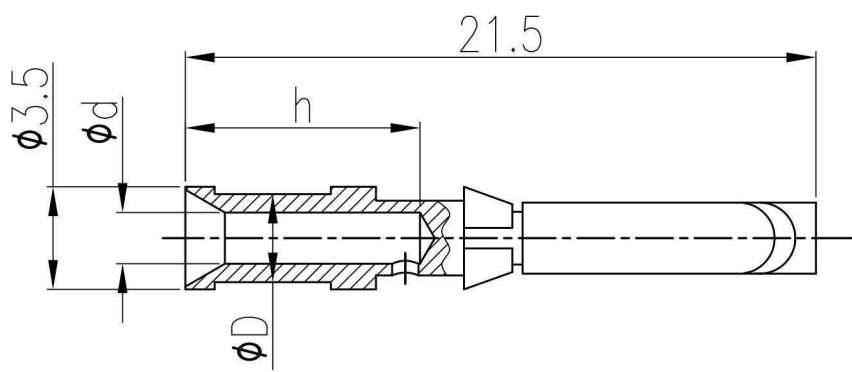

技术参数:

- 材料: 铜合金
- 表面处理: 镀银
- 额定电流: 10A
- 接触电阻: $\leq 3m\Omega$
- 线径范围: $0.14-2.5mm^2$ (26-14 AWG)
- 可插拔次数: ≥ 500

Technical specification:

- Material: copper alloy
- Surface: hard-silver plated
- Rated current: 10A
- Contact resistance: $\leq 3m\Omega$
- Wire gauge: $0.14-2.5mm^2$ (26-14 AWG)
- Mating cycles: ≥ 500

| | | | | | | | |
|---|--------------|------------------|----------------|-------------------|------------|---|--|
| 表面处理 Finish | | - | | 图号 Drawing No. | | - | |
| 材料 Material | | - | | 产品代号 Part Code | | CDSF-XX | |
| 标记 Mark | 处数 Number | 变更描述/Description | | 签名 Signature | 日期 Date | 产品料号 Part No. | |
| | 姓名/Name | 日期/Date | | 姓名/Name | 日期/Date | 产品名称 Part Name | |
| 绘图 Drawn | | | 标准化 Stand. | - | - | - | |
| 审核 Checked | | | | | | - | |
| 工艺 Process | - | - | 批准 Approved | | | - | |
| 比例 Scale | | 4:1 | | 版本 REV. | | V1.0 | |
| 重量 Weight | | - | | 数量 Qty. | | - | |
| All Dimensions in mm Original Size DIN A 4 | | | | | | 沈阳思沐源科技有限公司 Shenyang Simuyuan Technology Co., Ltd. | |