

1		2			3		4	
产品代号 Part code	产品料号 Part NO.	重量/Weight g	线径/Wire Gauge mm <sup>2</sup> AWG	d	D	剥线长度 Stripping length	标识 Identification	标识图 Identification No.
CESF-0.37		1.37	0.14-0.37 26-22	0.90	1.8	7.5	no groove	No.1
CESF-0.50		1.52	0.5 20	1.15	2.6	7.5	no groove	No.1
CESF-0.75		1.54	0.75 18	1.30	2.6	7.5	1 groove	No.2
CESF-1.0		1.54	1.0 18	1.45	2.6	7.5	1 groove	No.3
CESF-1.5		1.58	1.5 16	1.75	3.0	7.5	2 groove	No.4
CESF-2.5		1.62	2.5 14	2.25	3.5	7.5	3 groove	No.5
CESF-3.0		1.54	3.0 12	2.55	3.7	7.5	wide groove	No.6
CESF-4.0		1.55	4.0 12	2.85	3.9	7.5	no groove	No.1

5		6				
No.	No.1	No.2	No.3	No.4	No.5	No.6
标示图 Marked Graph						

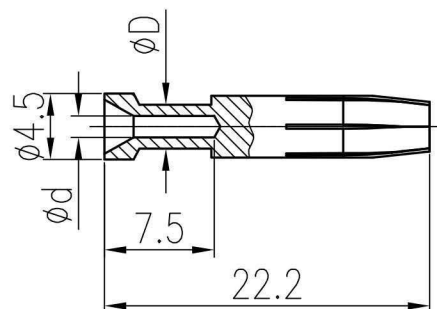

技术参数:

- 材料: 铜合金
- 表面处理: 镀银
- 额定电流: 16A
- 接触电阻: ≤1mΩ
- 线径范围: 0.14-4.0mm<sup>2</sup>(26-12 AWG)
- 可插拔次数: ≥500

Technical specification:

- Material: copper alloy
- Surface: hard-silver plated
- Rated current: 16A
- Contact resistance: ≤1mΩ
- Wire gauge: 0.14-4.0mm<sup>2</sup>(26-12 AWG)
- Mating cycles: ≥500

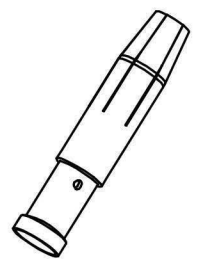

表面处理 Finish		-		图号 Drawing No.	-
材料 Material		-		产品代号 Part Code	CESF-XX
标记 Mark	处数 Number	变更描述/Description		签名 Signature	日期 Date
姓名/Name	日期/Date	姓名/Name	日期/Date	比例 Scale	版本 REV.
绘图 Drawn	审核 Checked	工艺 Process	批准 Approved	重量 Weight	数量 Qty.
				2:1	V1.0
				⊗	⊘
				All Dimensions in mm Original Size DIN A 4	
				 沈阳思沐源科技有限公司 Shenyang Simuyuan Technology Co., Ltd.	