

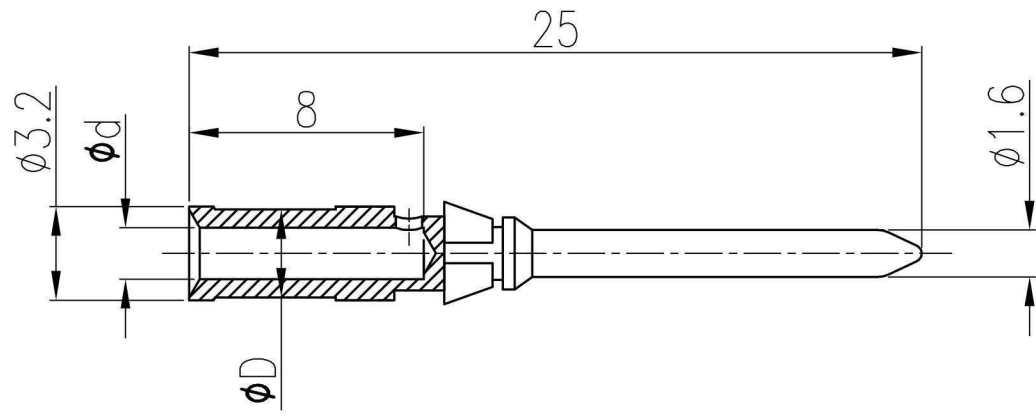

产品代号 Part Code	产品料号 Part NO.	重量/Weight			线径/Wire Gauge		剥线长度 Stripping Length
		g	mm ²	AWG	d	D	
CDSM-0.37		0.68	0.14-0.37	26-22	0.9	2.6	8
CDSM-0.50		0.66	0.5	20	1.15	2.6	8
CDSM-0.75		0.64	0.75	18	1.3	2.6	8
CDSM-1.0		0.62	1.0	18	1.45	2.6	8
CDSM-1.5		0.62	1.5	16	1.75	3.0	8

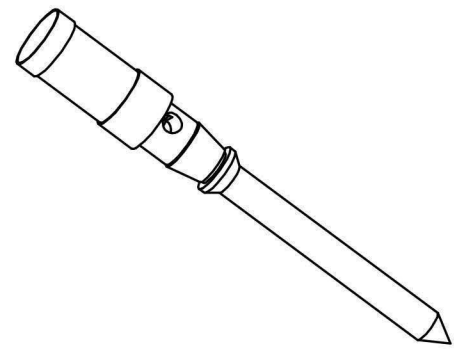

- 技术参数:
- 材料: 铜合金
 - 表面处理: 镀银
 - 额定电流: 10A
 - 接触电阻: $\leq 3m\Omega$
 - 线径范围: $0.14-1.5mm^2$ (26-16 AWG)
 - 可插拔次数: ≥ 500

- Technical specification:
- Material: copper alloy
 - Surface: hard-silver plated
 - Rated current: 10A
 - Contact resistance: $\leq 3m\Omega$
 - Wire gauge: $0.14-1.5mm^2$ (26-16 AWG)
 - Mating cycles: ≥ 500



表面处理 Finish		-		图号 Drawing No.	-	
材料 Material		-		产品代号 Part Code	CDSM-XX	
标记 Mark	处数 Number	变更描述/Description		签名 Signature	日期 Date	产品料号 Part No.
	姓名/Name	日期/Date		姓名/Name	日期/Date	产品名称 Part Name
绘图 Drawn			标准化 Stand.	-	-	
审核 Checked						
工艺 Process	-	-	批准 Approved			
比例 Scale		版本 REV.	重量 Weight	数量 Qty.	All Dimensions in mm Original Size DIN A 4	
4:1		V1.0	-	-	 沈阳思源科技有限公司 Shenyang Simuyuan Technology Co., Ltd.	